

Incartonatrice wrap-around compatta con alimentazione a 90° e stazione per l'introduzione manuale dell'alveare di cartone

Incartonatrice compatta
Mod. VF 100 COM /ALV

Conditionneuse carton compacte
Mod. VF 100 COM/ALV

Mod. VF 100 COM/ALV compact wrap-around case packer

90° feeding section and station for the manual insertion of cardboard divider

Encartonneuse wrap-around compacte avec alimentation à 90° et station d'introduction manuelle de l'alvéole cartonnée

Compact wrap-around case packer with 90° feeding section and station for the manual insertion of cardboard divider

CON METTI-ALVEARE MANUALE

AVEC POSITIONNEUR D'ALVÉOLE MANUEL

WITH MANUAL INSERTION OF CARDBOARD DIVIDER



- Sezione per l'introduzione manuale dell'alveare
- Station d'introduction manuelle de l'alvéole
- Station for manual insertion of cardboard divider

Mod.	A	B	C
VF 100	5500	2500	1450
VF 100 MP	5650	2600	1800
VF 100 ALV	7900	4900	1450

Tutte le quote sono da considerarsi in millimetri
Toutes les cotes sont exprimées en millimètres.
All measurements are in millimetres.

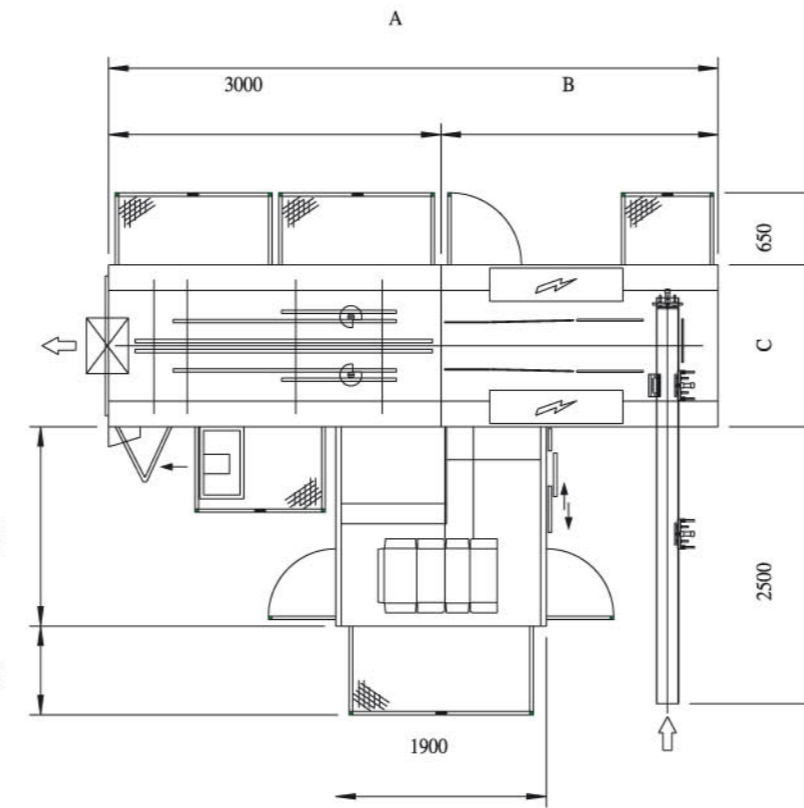

Mod.	A	B	C
VF 200	7500	4500	3750
VF 200 ALV	14500	11500	10750
VF 300	8500	5500	4750

Tutte le quote sono da considerarsi in millimetri
Toutes les cotes sont exprimées en millimètres.
All measurements are in millimetres.

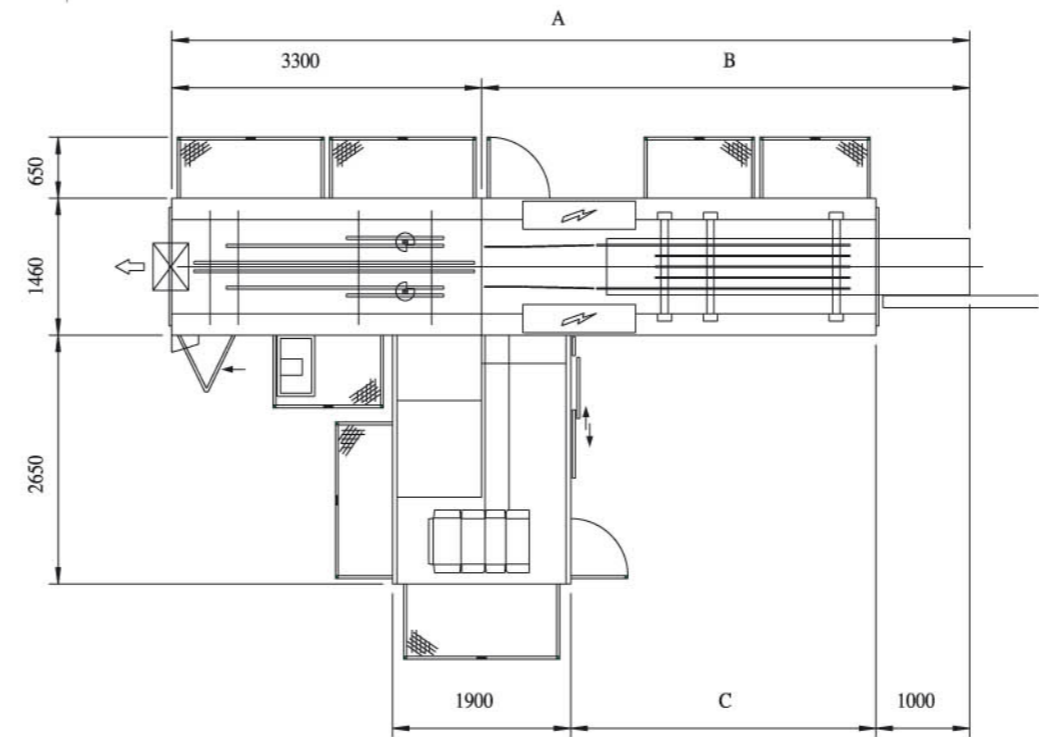

info@nolandcom.it



Impianti Novopac s.r.l.
Nuova Zona D3 • Via dell'Automobile, 41 • 15100 Alessandria • Italy
Tel. +39.0131.242111 • Fax +39.0131.240296
www.novopac.net - e-mail: info@novopac.net

Quote non impegnative

Cotes susceptibles de variation
Dimensions not binding



MACCHINE PER IMBALLAGGIO

MACHINES POUR EMBALLAGE
WRAPPING MACHINES



MOD. VF

MACCHINE PER IMBALLAGGIO

Mod. VF 100 / 200 / 300

Linee automatiche

per il confezionamento di prodotti cilindrici e parallelepipedi in scatola o vassoio wrap-around.

Lignes automatiques pour le conditionnement de produits cylindriques et parallelepipedes en carton ferme ou barquette.

Automatic packing lines for cylindrical square and rectangular products in cardboard tray or carton.



MOD. VF 200

Dati tecnici	Données techniques	Technical data		VF 100	VF 200	VF 300
Altezza piano di lavoro	Hauteur plan de travail	Working height	mm	1000	1000	1000
Peso macchina	Poids machine	Machine weight	-kg	3000	4000	5000
Alimentazione pneumatica	Alimentation pneumatique	Pneumatic feeding	atm	7	7	7
Consumo aria compressa per ciclo	Consommation d'air comprimé par cycle	Compressed air consumption per cycle	-NI	25	25	25
Alimentazione elettrica	Alimentation électrique	Electric feeding	Volts	230/400x3 - 50 Hz		
Potenza elettrica installata	Puissance élec. installée	Set up electric power	-KW	10	12	12
Produzione al min.	Production par min.	Output/min.	-	10	25	35

MOD. VF 100 COM



- Cambio formato facilitato tramite volantini numerici
- Changement de format facilité par l'utilisation de volants chiffre
- Change oversize operation made easier by metered handwheels

Incartonatrice wrap-around

Mod. VF 200 ALV con stazione di introduzione automatica dell'alveare

Encartonneuse wrap-around

Mod. VF200 ALV avec station d'introduction automatique de l'alvéole

Wrap-around case packer

Mod. VF 200 ALV with station for the automatic insertion of cardboard divider

Incartonatrice wrap-around compatta

con moto continuo Mod. VF 100

Encartonneuse wrap-around compacte

à mouvement continu Mod. VF 100

Compact wrap-around case packer

Mod. VF 100 continuous motion

